

## 12-BIT 4-CHANNEL SERIAL-OUTPUT SAMPLING ANALOG-TO-DIGITAL CONVERTER

### FEATURES

- Qualified for Automotive Applications
- Single Supply: 2.7 V To 5 V
- Four-Channel Single-Ended Or Two-Channel Differential Input
- Up To 200-kHz Conversion Rate
- $\pm 2$  LSB Max INL and DNL
- No Missing Codes
- 71-dB Typ SINAD
- Serial Interface
- Alternate Source For MAX1247

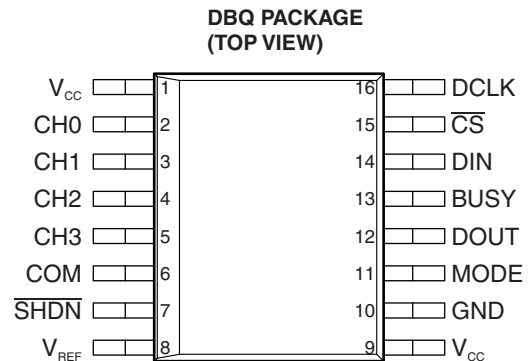

### DESCRIPTION

The ADS7841 is a 4-channel 12-bit sampling analog-to-digital converter (ADC) with a synchronous serial interface. The resolution is programmable to either 8 bits or 12 bits. Typical power dissipation is 2 mW at a 200-kHz throughput rate and a 5-V supply. The reference voltage ( $V_{REF}$ ) can be varied between 100 mV and  $V_{CC}$ , providing a corresponding input voltage range of 0 V to  $V_{REF}$ . The device includes a shutdown mode that reduces power dissipation to under 15  $\mu$ W. The ADS7841 is specified down to 2.7-V operation.

Low power, high speed, and on-board multiplexer make the ADS7841 ideal for battery-operated systems. The serial interface also provides low-cost isolation for remote data acquisition. The ADS7841 is available in a SSOP-16 package and is specified over the  $-40^{\circ}\text{C}$  to  $85^{\circ}\text{C}$  temperature range.

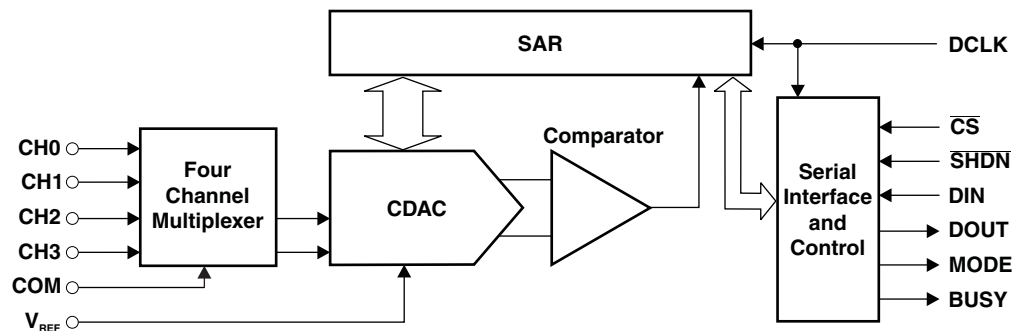

Please be aware that an important notice concerning availability, standard warranty, and use in critical applications of Texas Instruments semiconductor products and disclaimers thereto appears at the end of this data sheet.



This integrated circuit can be damaged by ESD. Texas Instruments recommends that all integrated circuits be handled with appropriate precautions. Failure to observe proper handling and installation procedures can cause damage.

ESD damage can range from subtle performance degradation to complete device failure. Precision integrated circuits may be more susceptible to damage because very small parametric changes could cause the device not to meet its published specifications.

**ORDERING INFORMATION<sup>(1)</sup>**

T <sub>A</sub>	PACKAGE <sup>(2)</sup>		ORDERABLE PART NUMBER	TOP-SIDE MARKING
-40°C to 85°C	SSOP – DBQ	Reel of 2500	ADS7841EIDBQRQ1	ADS7841E

- (1) For the most current package and ordering information, see the Package Option Addendum at the end of this document, or see the TI web site at [www.ti.com](http://www.ti.com).
- (2) Package drawings, thermal data, and symbolization are available at [www.ti.com/packaging](http://www.ti.com/packaging).

**TERMINAL FUNCTIONS**

TERMINAL		I/O	DESCRIPTION
NAME	NO.		
V <sub>CC</sub>	1		Power supply
CH0	2	I	Analog input channel 0
CH1	3	I	Analog input channel 1
CH2	4	I	Analog input channel 2
CH3	5	I	Analog input channel 3
COM	6	I	Ground reference for analog inputs. Sets zero code voltage in single-ended mode. Connect this pin to ground or ground reference point.
$\overline{\text{SHDN}}$	7	I	Shutdown. When low, the device enters a very low power shutdown mode.
V <sub>REF</sub>	8	I	Voltage reference
V <sub>CC</sub>	9		Power supply
GND	10		Ground
MODE	11	I	Conversion mode. When low, the device always performs a 12-bit conversion. When high, the resolution is set by the MODE bit in the CONTROL byte.
DOUT	12	O	Serial data output. Data is shifted on the falling edge of DCLK. This output is high-impedance when $\overline{\text{CS}}$ is high.
BUSY	13	O	Busy output. This output is high-impedance when $\overline{\text{CS}}$ is high.
DIN	14	I	Serial data input. If $\overline{\text{CS}}$ is low, data is latched on rising edge of DCLK.
$\overline{\text{CS}}$	15	I	Chip select input. Controls conversion timing and enables the serial input/output register.
DCLK	16	I	External clock input. This clock runs the SAR conversion process and synchronizes serial data I/O.

## ABSOLUTE MAXIMUM RATINGS<sup>(1)</sup>

over operating free-air temperature range (unless otherwise noted)

$V_{CC}$	Supply voltage		–0.3 V to 6 V
$V_{IN}$	Input voltage	Analog inputs to GND	–0.3 V to ( $V_{CC} + 0.3$ V)
		Digital inputs to GND	–0.3 V to 6 V
$P_D$	Power dissipation		250 mW
$T_J$	Maximum virtual-junction temperature		150°C
$T_A$	Operating free-air temperature range		–40°C to 85°C
$T_{stg}$	Storage temperature range		–65°C to 150°C

(1) Stresses beyond those listed under *absolute maximum ratings* may cause permanent damage to the device. These are stress ratings only, and functional operation of the device at these or any other conditions beyond those indicated under *recommended operating conditions* is not implied. Exposure to absolute-maximum-rated conditions for extended periods may affect device reliability.

## ELECTROSTATIC DISCHARGE RATINGS

		RATING	
ESD	Electrostatic discharge rating	Human-Body Model (HBM)	1500 V
		Machine Model (MM)	100 V
		Charged-Device Model (CDM)	1000 V

## RECOMMENDED OPERATING CONDITIONS

over operating free-air temperature range (unless otherwise noted)

			MIN	MAX	UNIT	
$V_{CC}$	Supply voltage	$V_{CC} = 5$ V (nom)	4.75	5.25	V	
		$V_{CC} = 2.7$ V (nom)	2.7	3.6		
$V_{REF}$	Reference voltage, $V_{REF}$ terminal		0.1	$V_{CC}$	V	
$V_{IN}$	Input voltage, analog inputs	Differential, full-scale	0	$V_{REF}$	V	
		Positive input	–0.2	$V_{CC} + 0.2$		
		Negative input	$V_{CC} = 5$ V (nom)	–0.2		1.25
			$V_{CC} = 2.7$ V (nom)	–0.2	0.2	
$V_{IH}$	High-level input voltage, digital inputs	$ I_{IH}  \leq 5$ $\mu$ A	$V_{CC} = 5$ V (nom)	3	5.5	V
			$V_{CC} = 2.7$ V (nom)	0.7 $V_{CC}$	5.5	
$V_{IL}$	Low-level input voltage, digital inputs	$ I_{IL}  \leq 5$ $\mu$ A	$V_{CC} = 5$ V (nom)	–0.3	0.8	V
			$V_{CC} = 2.7$ V (nom)	–0.3	0.8	
$T_A$	Operating free-air temperature		–40	85	°C	

**ELECTRICAL CHARACTERISTICS**

$V_{CC} = 5\text{ V}$ ,  $V_{REF} = 5\text{ V}$ ,  $f_{SAMPLE} = 200\text{ kHz}$ ,  $f_{CLK} = 16 \times f_{SAMPLE} = 3.2\text{ MHz}$ , over operating free-air temperature range (unless otherwise noted)

PARAMETER		TEST CONDITIONS	MIN	TYP	MAX	UNIT
<b>Analog Input</b>						
$C_I$	Input capacitance			25		pF
$I_{leak}$	Leakage current				200	nA
<b>System Performance</b>						
	Resolution			12		bits
	No missing codes		12			bits
INL	Integral linearity error				$\pm 2$	LSB <sup>(1)</sup>
DNL	Differential linearity error			$\pm 0.8$		LSB
	Offset error				$\pm 3$	LSB
	Offset error match			0.15	1	LSB
	Gain error				$\pm 4$	LSB
	Gain error match			0.1	1	LSB
$V_n$	Noise			30		$\mu V_{rms}$
PSRR	Power-supply ripple rejection			70		dB
<b>Sampling Dynamics</b>						
$t_{conv}$	Conversion time				12	CLK cycles
$t_{acq}$	Acquisition time		3			CLK cycles
	Throughput rate				200	kHz
$t_{settle}$	Multiplexer settling time			500		ns
$t_d$	Aperture delay			30		ns
$t_{jitter}$	Aperture jitter			100		ps
<b>Dynamic Characteristics</b>						
THD	Total harmonic distortion <sup>(2)</sup>	$V_{IN} = 5\text{ V}_{p-p}$ at 10 kHz		-78	-72	dB
SINAD	Signal to noise + distortion ratio	$V_{IN} = 5\text{ V}_{p-p}$ at 10 kHz	68	71		dB
	Spurious-free dynamic range	$V_{IN} = 5\text{ V}_{p-p}$ at 10 kHz	72	79		dB
	Channel-to-channel isolation	$V_{IN} = 5\text{ V}_{p-p}$ at 50 kHz		120		dB
<b>Reference Input</b>						
$R_I$	Resistance	DCLK static		5		G $\Omega$
$I_I$	Input current			40	100	$\mu A$
		$f_{SAMPLE} = 12.5\text{ kHz}$		2.5		
		DCLK static		0.001	3	
<b>Digital Input/Output</b>						
$V_{OH}$	High-level output voltage	$I_{OH} = -250\text{ }\mu A$	3.5			V
$V_{OL}$	Low-level output voltage	$I_{OL} = 250\text{ }\mu A$			0.4	V
<b>Power Supply</b>						
$I_Q$	Quiescent current			550	900	$\mu A$
		$f_{SAMPLE} = 12.5\text{ kHz}$		300		
		Power-down mode <sup>(3)</sup> , $\overline{CS} = V_{CC}$			3	

(1) LSB = least significant bit. With  $V_{REF} = 5\text{ V}$ , one LSB is 1.22 mV.  
 (2) First five harmonics of the test frequency  
 (3) Auto power-down mode (PD1 = PD0 = 0) active or  $\overline{SHDN} = GND$

## ELECTRICAL CHARACTERISTICS

$V_{CC} = 2.7\text{ V}$ ,  $V_{REF} = 2.5\text{ V}$ ,  $f_{SAMPLE} = 125\text{ kHz}$ ,  $f_{CLK} = 16 \times f_{SAMPLE} = 2\text{ MHz}$ , over operating free-air temperature range (unless otherwise noted)

PARAMETER		TEST CONDITIONS	MIN	TYP	MAX	UNIT
<b>Analog Input</b>						
$C_I$	Input capacitance			25		pF
$I_{leak}$	Leakage current			±1		μA
<b>System Performance</b>						
	Resolution			12		bits
	No missing codes		12			bits
INL	Integral linearity error				±2	LSB <sup>(1)</sup>
DNL	Differential linearity error			±0.8		LSB
	Offset error				±3	LSB
	Offset error match			0.15	1	LSB
	Gain error				±4	LSB
	Gain error match			0.1	1	LSB
$V_n$	Noise			30		μV <sub>rms</sub>
PSRR	Power-supply ripple rejection			70		dB
<b>Sampling Dynamics</b>						
$t_{conv}$	Conversion time				12	CLK cycles
$t_{acq}$	Acquisition time		3			CLK cycles
	Throughput rate				125	kHz
$t_{settle}$	Multiplexer settling time			500		ns
$t_d$	Aperture delay			30		ns
$t_{jitter}$	Aperture jitter			100		ps
<b>Dynamic Characteristics</b>						
THD	Total harmonic distortion <sup>(2)</sup>	$V_{IN} = 2.5\text{ V}_{p-p}$ at 10 kHz		-77	-72	dB
SINAD	Signal to noise + distortion ratio	$V_{IN} = 2.5\text{ V}_{p-p}$ at 10 kHz	68	71		dB
	Spurious-free dynamic range	$V_{IN} = 2.5\text{ V}_{p-p}$ at 10 kHz	72	78		dB
	Channel-to-channel isolation	$V_{IN} = 2.5\text{ V}_{p-p}$ at 50 kHz		100		dB
<b>Reference Input</b>						
$R_I$	Resistance	DCLK static		5		GΩ
$I_I$	Input current			13	40	μA
		$f_{SAMPLE} = 12.5\text{ kHz}$		2.5		
		DCLK static		0.001	3	
<b>Digital Input/Output</b>						
$V_{OH}$	High-level output voltage	$I_{OH} = -250\text{ μA}$	0.8 $V_{CC}$			V
$V_{OL}$	Low-level output voltage	$I_{OL} = 250\text{ μA}$			0.4	V
<b>Power Supply</b>						
$I_Q$	Quiescent current			280	650	μA
		$f_{SAMPLE} = 12.5\text{ kHz}$		220		
		Power-down mode <sup>(3)</sup> , $\overline{CS} = V_{CC}$			3	

(1) LSB = least significant bit. With  $V_{REF} = 2.5\text{ V}$ , one LSB is 0.61 mV.

(2) First five harmonics of the test frequency

(3) Auto power-down mode (PD1 = PD0 = 0) active or  $\overline{SHDN} = \text{GND}$

**TYPICAL CHARACTERISTICS,  $V_{CC} = 5\text{ V}$**

$V_{CC} = 5\text{ V}$ ,  $T_A = 25^\circ\text{C}$ ,  $V_{REF} = 5\text{ V}$ ,  $f_{SAMPLE} = 200\text{ kHz}$ ,  $f_{CLK} = 16 \times f_{SAMPLE} = 3.2\text{ MHz}$  (unless otherwise noted)

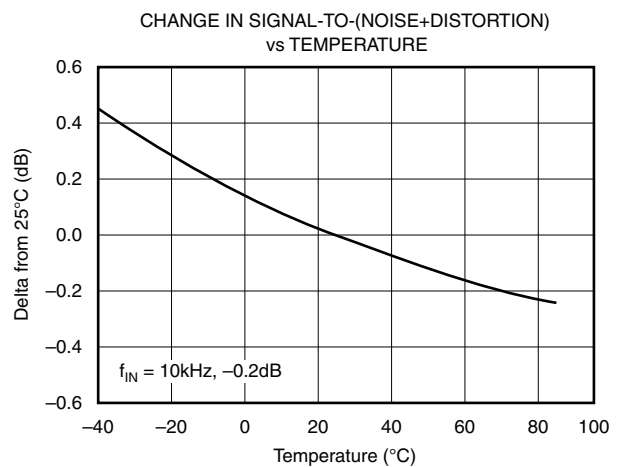
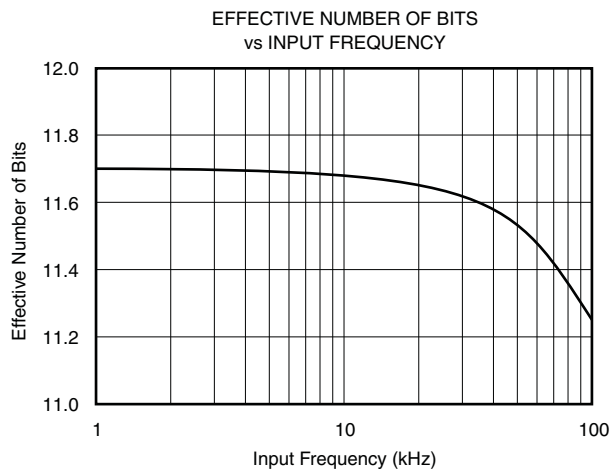
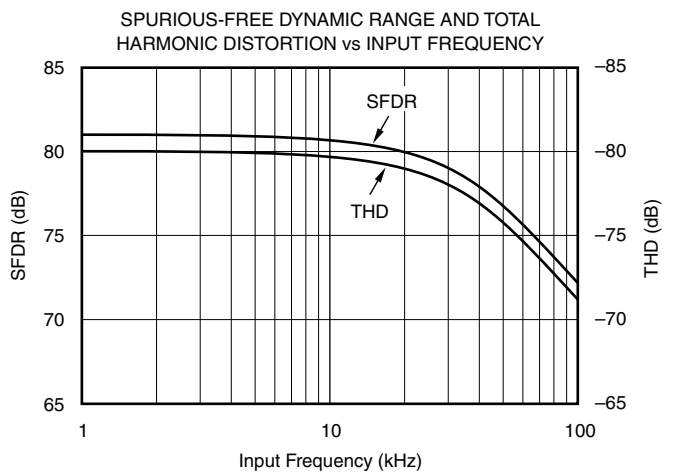
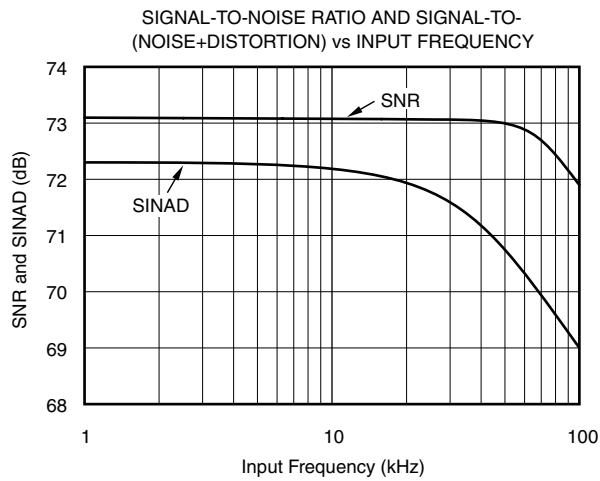
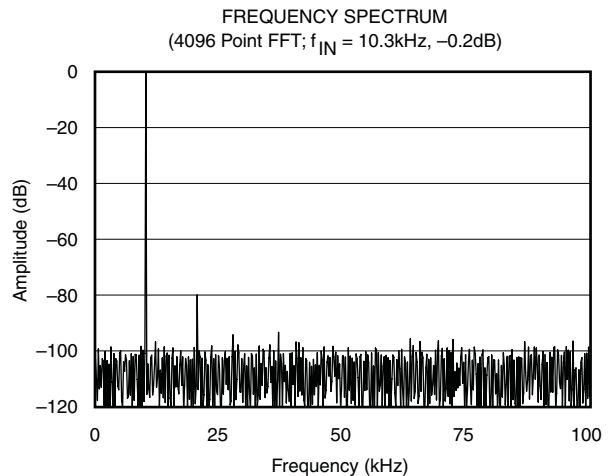
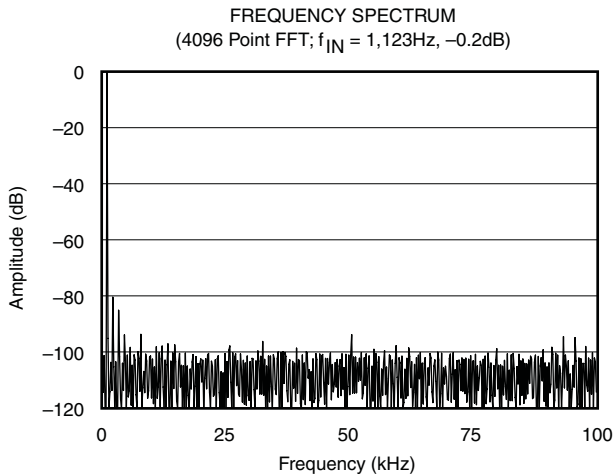

**TYPICAL CHARACTERISTICS,  $V_{CC} = 2.7\text{ V}$**

$V_{CC} = 2.7\text{ V}$ ,  $T_A = 25^\circ\text{C}$ ,  $V_{REF} = 2.5\text{ V}$ ,  $f_{SAMPLE} = 125\text{ kHz}$ ,  $f_{CLK} = 16 \times f_{SAMPLE} = 2\text{ MHz}$  (unless otherwise noted)

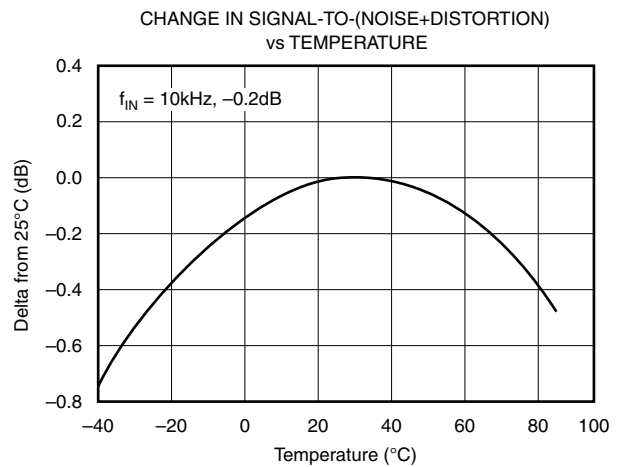
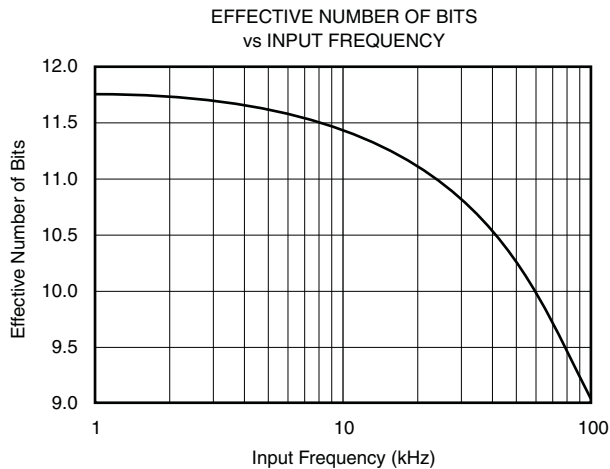
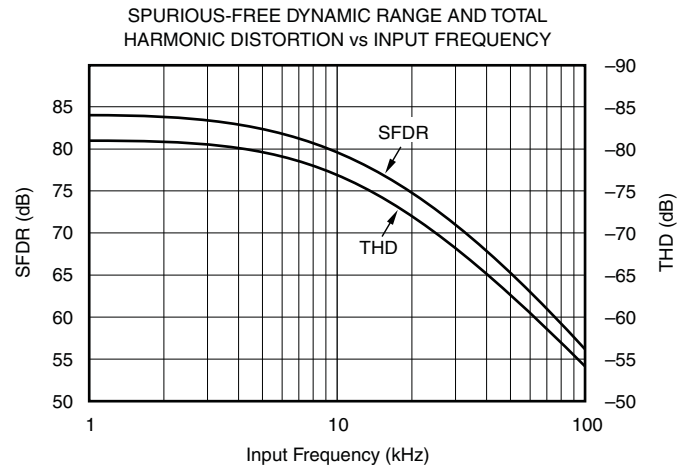
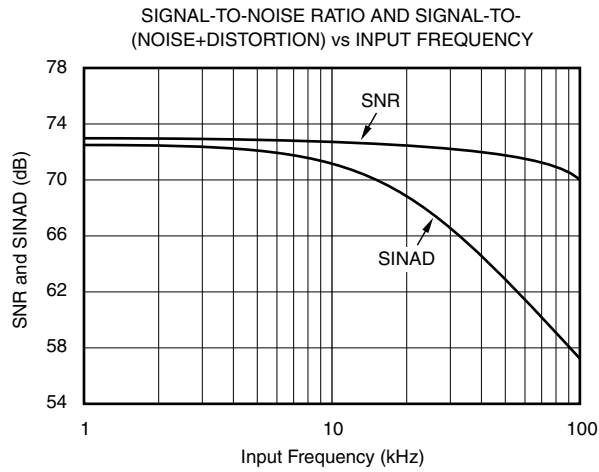
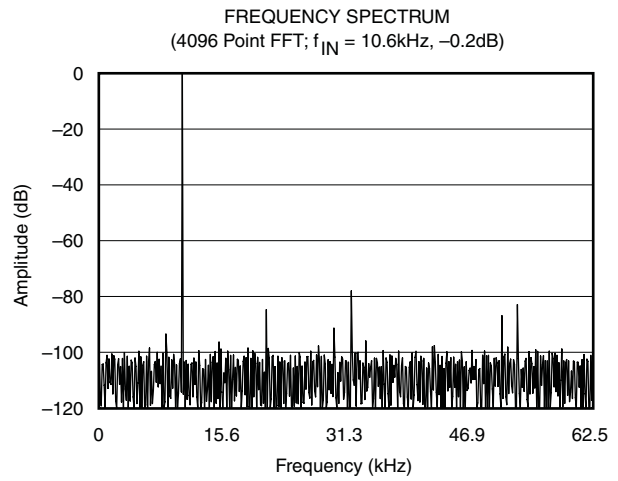
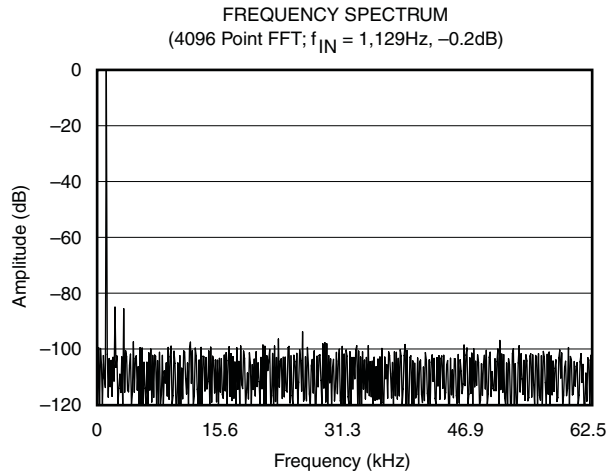

**TYPICAL CHARACTERISTICS,  $V_{CC} = 2.7\text{ V}$  (continued)**

$V_{CC} = 2.7\text{ V}$ ,  $T_A = 25^\circ\text{C}$ ,  $V_{REF} = 2.5\text{ V}$ ,  $f_{SAMPLE} = 125\text{ kHz}$ ,  $f_{CLK} = 16 \times f_{SAMPLE} = 2\text{ MHz}$  (unless otherwise noted)

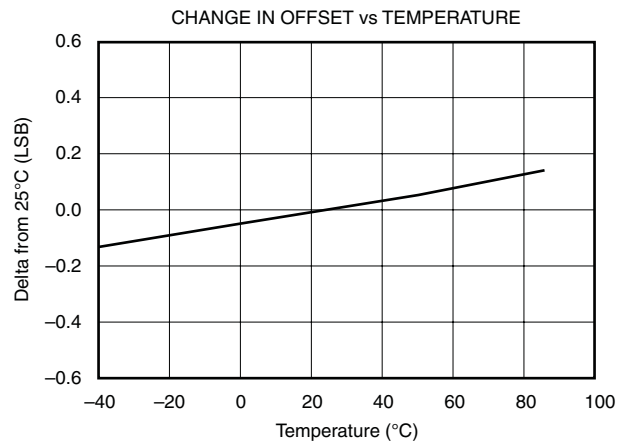
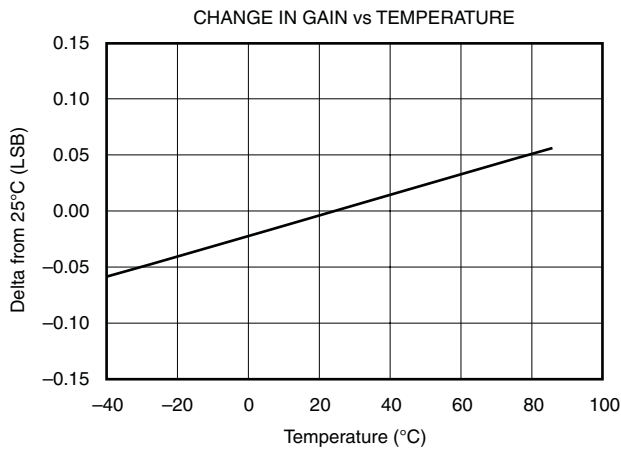
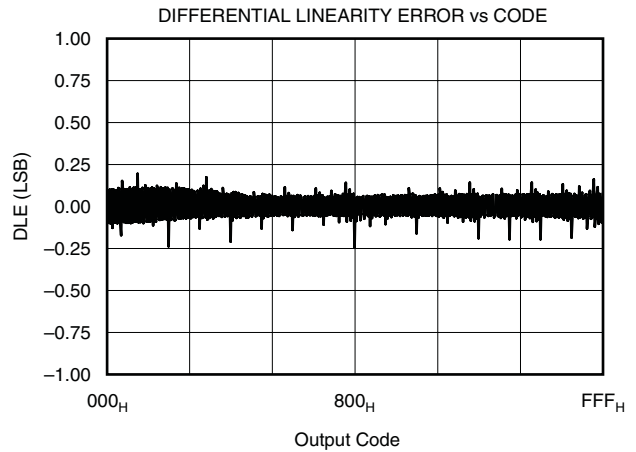
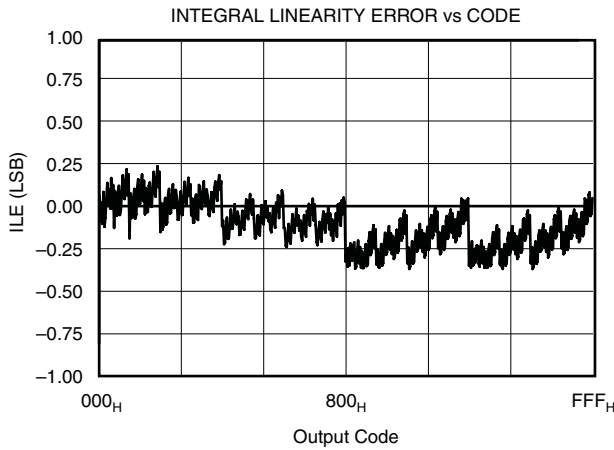
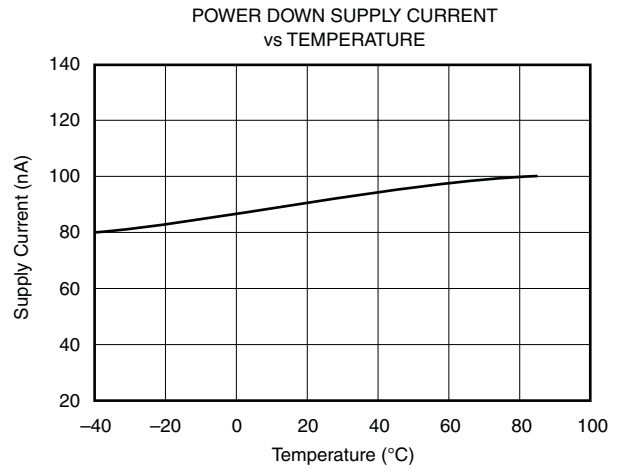
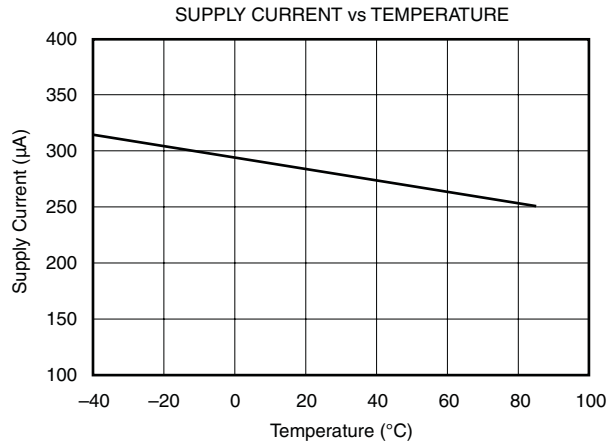

**TYPICAL CHARACTERISTICS,  $V_{CC} = 2.7\text{ V}$  (continued)**

$V_{CC} = 2.7\text{ V}$ ,  $T_A = 25^\circ\text{C}$ ,  $V_{REF} = 2.5\text{ V}$ ,  $f_{SAMPLE} = 125\text{ kHz}$ ,  $f_{CLK} = 16 \times f_{SAMPLE} = 2\text{ MHz}$  (unless otherwise noted)

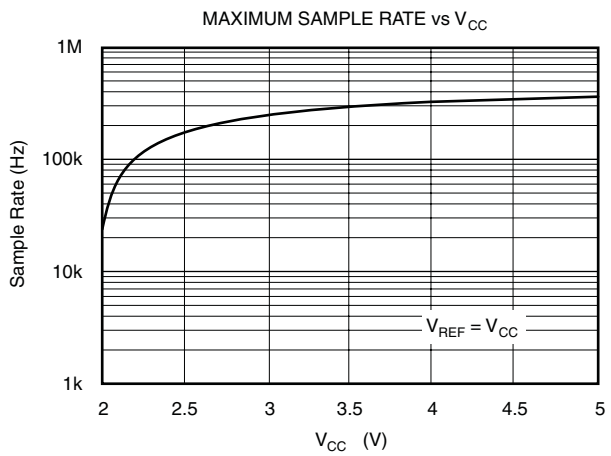
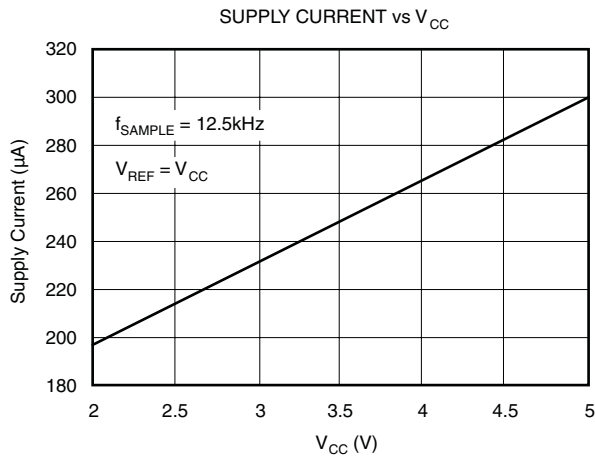
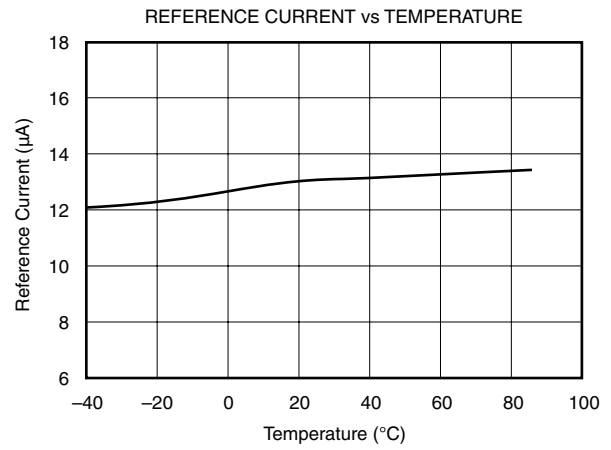
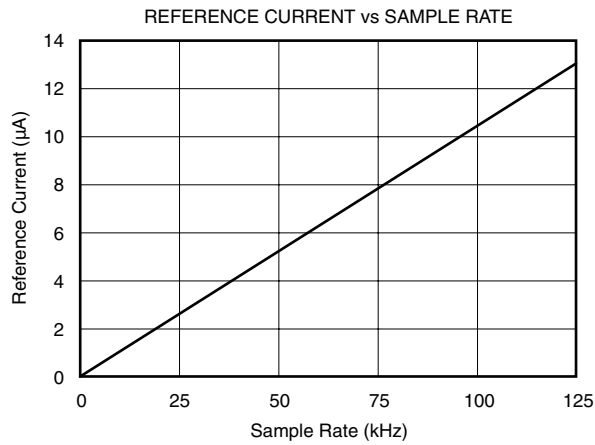

### APPLICATION INFORMATION

The ADS7841 is a classic successive approximation register (SAR) ADC. The architecture is based on capacitive redistribution that inherently includes a sample-and-hold function. The converter is fabricated on a 0.6- $\mu\text{s}$  CMOS process.

The basic operation of the ADS7841 is shown in [Figure 1](#). The device requires an external reference and an external clock. It operates from a single supply of 2.7 V to 5.25 V. The external reference can be any voltage between 100 mV and  $V_{CC}$ . The value of the reference voltage directly sets the input range of the converter. The average reference input current depends on the conversion rate of the ADS7841.

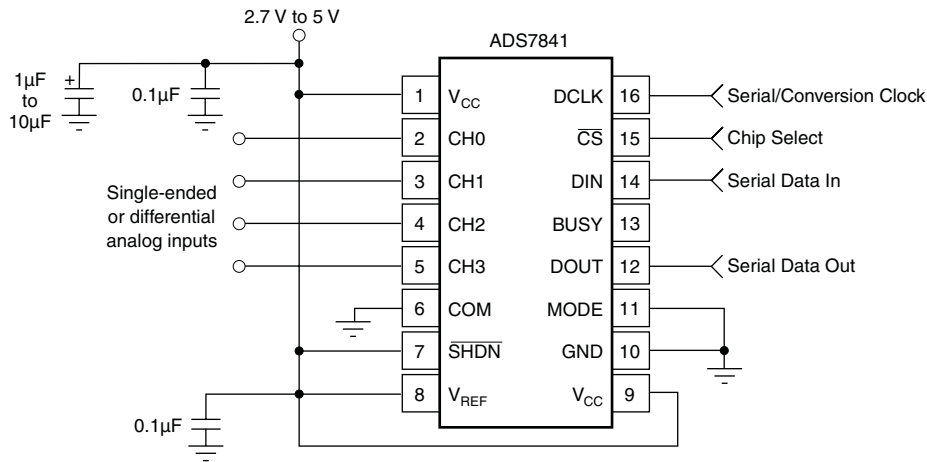
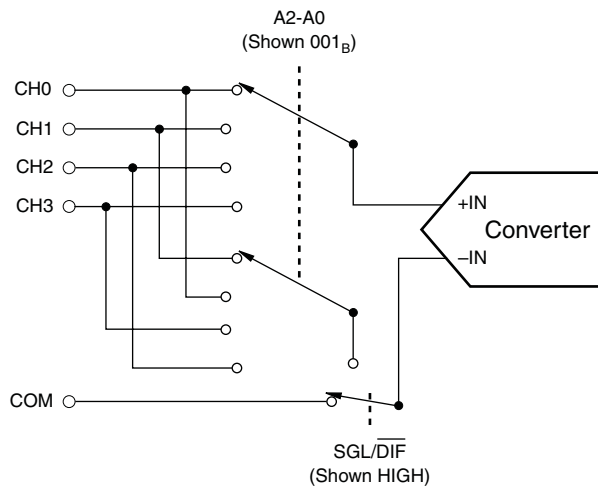

**Figure 1. Basic Operation of the ADS7841**

The analog input to the converter is differential and is provided via a four-channel multiplexer. The input can be provided in reference to a voltage on the COM pin (which is generally ground) or differentially by using two of the four input channels (CH0-CH3). The particular configuration is selectable via the digital interface.

### Analog Input

[Figure 2](#) shows a block diagram of the input multiplexer on the ADS7841. The differential input of the converter is derived from one of the four inputs in reference to the COM pin or two of the four inputs. [Table 1](#) and [Table 2](#) show the relationship between the A2, A1, A0, and SGL/DIF control bits and the configuration of the analog multiplexer. The control bits are provided serially via the DIN pin, see the Digital Interface section of this data sheet for more details.



**Figure 2. Simplified Diagram of the Analog Input**

**Table 1. Single-Ended Channel Selection (SGL/DIF high)**

A2	A1	A0	CH0	CH1	CH2	CH3	COM
0	0	1	+IN				–IN
1	0	1		+IN			–IN
0	1	0			+IN		–IN
1	1	0				+IN	–IN

**Table 2. Differential Channel Control (SGL/DIF low)**

A2	A1	A0	CH0	CH1	CH2	CH3	COM
0	0	1	+IN	–IN			
1	0	1	–IN	+IN			
0	1	0			+IN	–IN	
1	1	0			–IN	+IN	

When the converter enters the hold mode, the voltage difference between the +IN and –IN inputs (as shown in [Figure 2](#)) is captured on the internal capacitor array. The voltage on the –IN input is limited between –0.2 V and 1.25 V, allowing the input to reject small signals that are common to both the +IN and –IN input. The +IN input has a range of –0.2 V to  $V_{CC} + 0.2$  V.

The input current on the analog inputs depends on the conversion rate of the device. During the sample period, the source must charge the internal sampling capacitor (typically 25 pF). After the capacitor has been fully charged, there is no further input current. The rate of charge transfer from the analog source to the converter is a function of conversion rate.

## Reference Input

The external reference sets the analog input range. The ADS7841 operates with a reference in the range of 100 mV to  $V_{CC}$ . Keep in mind that the analog input is the difference between the +IN input and the –IN input, see [Figure 2](#). For example, in the single-ended mode, a 1.25-V reference, and with the COM pin grounded, the selected input channel (CH0-CH3) digitizes a signal in the range of 0 V to 1.25 V. If the COM pin is connected to 0.5 V, the input range on the selected channel is 0.5 V to 1.75 V.

There are several critical items concerning the reference input and its wide voltage range. As the reference voltage is reduced, the analog voltage weight of each digital output code is also reduced. This is often referred to as the LSB (least significant bit) size and is equal to the reference voltage divided by 4096. Any offset or gain error inherent in the ADC appears to increase, in terms of LSB size, as the reference voltage is reduced. For example, if the offset of a given converter is 2 LSBs with a 2.5-V reference, then it is typically 10 LSBs with a 0.5-V reference. In each case, the actual offset of the device is the same, 1.22 mV.

Likewise, the noise or uncertainty of the digitized output increases with lower LSB size. With a reference voltage of 100 mV, the LSB size is 24  $\mu$ V. This level is below the internal noise of the device. As a result, the digital output code is not stable and varies around a mean value by a number of LSBs. The distribution of output codes is gaussian, and the noise can be reduced by simply averaging consecutive conversion results or applying a digital filter.

With a lower reference voltage, care should be taken to provide a clean layout including adequate bypassing, a clean (low-noise, low-ripple) power supply, a low-noise reference, and a low-noise input signal. Because the LSB size is lower, the converter is also more sensitive to nearby digital signals and electromagnetic interference.

The voltage into the  $V_{REF}$  input is not buffered and directly drives the Capacitor Digital-to-Analog Converter (CDAC) portion of the ADS7841. Typically, the input current is 13  $\mu$ A with a 2.5-V reference. This value varies by microamps depending on the result of the conversion. The reference current diminishes directly with both conversion rate and reference voltage. As the current from the reference is drawn on each bit decision, clocking the converter more quickly during a given conversion period does not reduce overall current drain from the reference.

### Digital Interface

Figure 3 shows the typical operation of the ADS7841's digital interface. This diagram assumes that the source of the digital signals is a microcontroller or digital signal processor with a basic serial interface (note that the digital inputs are over-voltage tolerant up to 5.5 V, regardless of  $V_{CC}$ ). Each communication between the processor and the converter consists of eight clock cycles. One complete conversion can be accomplished with three serial communications, for a total of 24 clock cycles on the DCLK input.

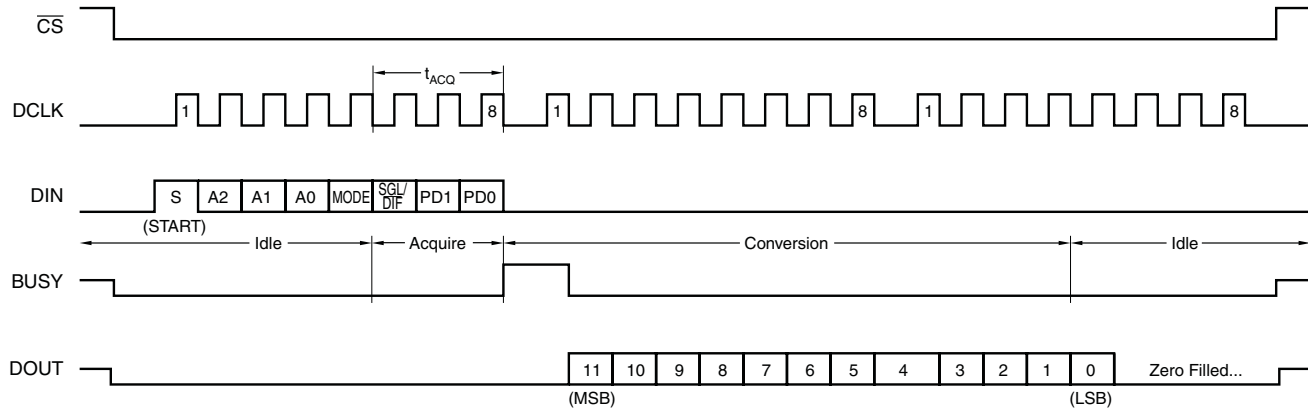

A. 24 clock cycles per conversion, 8-bit bus interface. No DCLK delay required with dedicated serial port.

**Figure 3. Conversion Timing**

The first eight clock cycles are used to provide the control byte via the DIN pin. When the converter has enough information about the following conversion to set the input multiplexer appropriately, it enters the acquisition (sample) mode. After three more clock cycles, the control byte is complete and the converter enters the conversion mode. At this point, the input sample-and-hold goes into the hold mode. The next twelve clock cycles accomplish the actual Analog-to-Digital conversion. A thirteenth clock cycle is needed for the last bit of the conversion result. Three more clock cycles are needed to complete the last byte (DOUT is low). These are ignored by the converter.

### Control Byte

Also shown in Figure 3 is the placement and order of the control bits within the control byte. Table 3 and Table 4 give detailed information about these bits. The first bit, the 'S' bit, must always be high and indicates the start of the control byte. The ADS7841 ignores inputs on the DIN pin until the start bit is detected. The next three bits (A2-A0) select the active input channel or channels of the input multiplexer (see Table 1, Table 2, and Figure 2).

**Table 3. Order of Control Bits in Control Byte**

Bit 7 (MSB)	Bit 6	Bit 5	Bit 4	Bit 3	Bit 2	Bit 1	Bit 0 (LSB)
S	A2	A1	A0	MODE	SGL/DIF	PD1	PD0

**Table 4. Descriptions of Control Bits Within Control Byte**

BIT	NAME	DESCRIPTION
7	S	Start bit. Control byte starts with first high bit on DIN. A new control byte can start every 15th clock cycle in 12-bit conversion mode or every 11th clock cycle in 8-bit conversion mode.
6-4	A2-A0	Channel select bits. Along with the SGL/DIF bit, these bits control the setting of the multiplexer input, see Table 1 and Table 2.
3	MODE	12-bit/8-bit conversion select bit. If the MODE pin is high, this bit controls the number of bits for the next conversion: 12-bits (low) or 8-bits (high). If the MODE pin is low, this bit has no function and the conversion is always 12 bits.
2	SGL/DIF	Single-ended/differential select bit. Along with bits A2-A0, this bit controls the setting of the multiplexer input, see Table 1 and Table 2.
1-0	PD1-PD0	Power-down mode select bits. See Table 5 for details.

The MODE bit and the MODE pin work together to determine the number of bits for a given conversion. If the MODE pin is low, the converter always performs a 12-bit conversion regardless of the state of the MODE bit. If the MODE pin is high, then the MODE bit determines the number of bits for each conversion, either 12 bits (low) or 8 bits (high).

The SGL/DIF bit controls the multiplexer input mode: either single-ended (high) or differential (low). In single-ended mode, the selected input channel is referenced to the COM pin. In differential mode, the two selected inputs provide a differential input. See Table 1, Table 2, and Figure 2 for more information. The last two bits (PD1-PD0) select the powerdown mode, as shown in Table 5. If both inputs are high, the device is always powered up. If both inputs are low, the device enters a power-down mode between conversions. When a new conversion is initiated, the device resumes normal operation instantly—no delay is needed to allow the device to power up and the very first conversion is valid.

**Table 5. Power-Down Selection**

PD1	PD0	DESCRIPTION
0	0	Power-down between conversions. When each conversion is finished, the converter enters a low power mode. At the start of the next conversion, the device instantly powers up to full power. There is no need for additional delays to assure full operation and the very first conversion is valid.
0	1	Reserved
1	0	Reserved
1	1	No power-down between conversions, device always powered.

**16 Clock Cycles Per Conversion**

The control bits for conversion n+1 can be overlapped with conversion 'n' to allow for a conversion every 16 clock cycles, as shown in Figure 4. This figure also shows possible serial communication occurring with other serial peripherals between each byte transfer between the processor and the converter. This is possible provided that each conversion completes within 1.6ms of starting. Otherwise, the signal that has been captured on the input sample-and-hold may droop enough to affect the conversion result. In addition, the ADS7841 is fully powered while other serial communications are taking place.

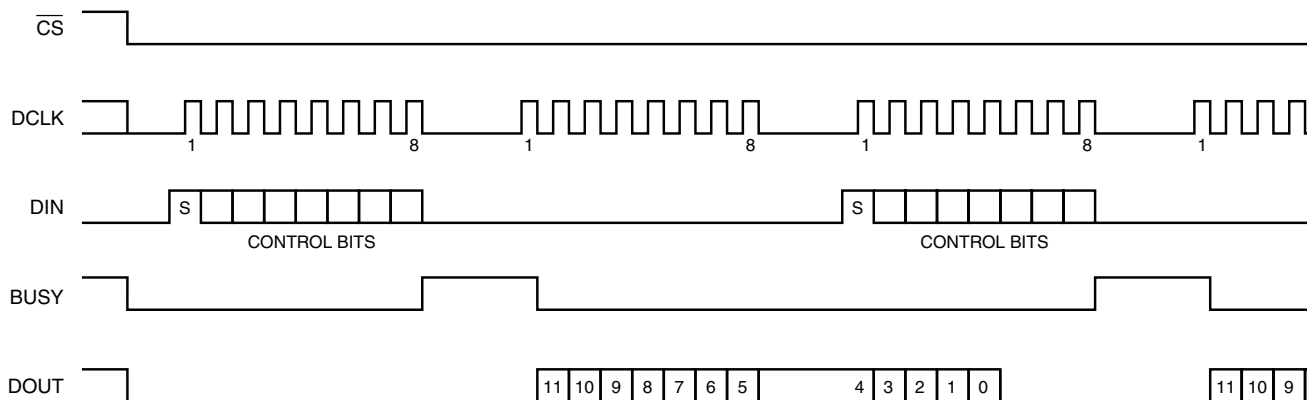

A. 16 clock cycles per conversion, 8-bit bus interface. No DCLK delay required with dedicated serial port.

**Figure 4. Conversion Timing**

Digital Timing

Figure 5, Table 6, and Table 7 provide detailed timing for the digital interface of the ADS7841.

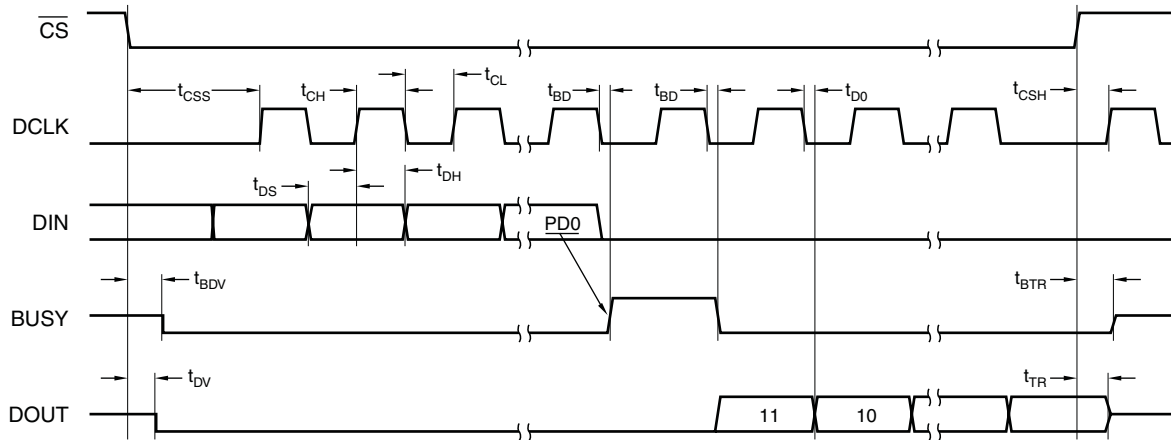

Figure 5. Detailed Timing Diagram

Table 6. Timing Specifications,  $V_{CC} = 2.7\text{ V to }3.6\text{ V}$ ,  $T_A = -40^\circ\text{C to }85^\circ\text{C}$ ,  $C_{LOAD} = 50\text{ pF}$

SYMBOL	DESCRIPTION	MIN	MAX	UNIT
$t_{ACQ}$	Acquisition time	1500		ns
$t_{DS}$	DIN valid prior to DCLK rising	100		ns
$t_{DH}$	DIN hold after DCLK high	10		ns
$t_{DO}$	DCLK falling to DOUT valid		200	ns
$t_{DV}$	$\overline{CS}$ falling to DOUT enabled		200	ns
$t_{TR}$	$\overline{CS}$ rising to DOUT disabled		200	ns
$t_{CSS}$	$\overline{CS}$ falling to first DCLK rising	100		ns
$t_{CSH}$	$\overline{CS}$ rising to DCLK ignored	0		ns
$t_{CH}$	DCLK high	200		ns
$t_{CL}$	DCLK low	200		ns
$t_{BD}$	DCLK falling to BUSY rising		200	ns
$t_{BDV}$	$\overline{CS}$ falling to BUSY enabled		200	ns
$t_{BTR}$	$\overline{CS}$ rising to BUSY disabled		200	ns

Table 7. Timing Specifications,  $V_{CC} = 4.75\text{ V to }5.25\text{ V}$ ,  $T_A = -40^\circ\text{C to }85^\circ\text{C}$ ,  $C_{LOAD} = 50\text{ pF}$

SYMBOL	DESCRIPTION	MIN	MAX	UNIT
$t_{ACQ}$	Acquisition time	900		ns
$t_{DS}$	DIN valid prior to DCLK rising	50		ns
$t_{DH}$	DIN hold after DCLK high	10		ns
$t_{DO}$	DCLK falling to DOUT valid		100	ns
$t_{DV}$	$\overline{CS}$ falling to DOUT enabled		70	ns
$t_{TR}$	$\overline{CS}$ rising to DOUT disabled		70	ns
$t_{CSS}$	$\overline{CS}$ falling to first DCLK rising	50		ns
$t_{CSH}$	$\overline{CS}$ rising to DCLK ignored	0		ns
$t_{CH}$	DCLK high	150		ns
$t_{CL}$	DCLK low	150		ns
$t_{BD}$	DCLK falling to BUSY rising		100	ns
$t_{BDV}$	$\overline{CS}$ falling to BUSY enabled		70	ns
$t_{BTR}$	$\overline{CS}$ rising to BUSY disabled		70	ns

### 15 Clock Cycles Per Conversion

Figure 6 provides the fastest way to clock the ADS7841. This method does not work with the serial interface of most microcontrollers and digital signal processors as they are generally not capable of providing 15 clock cycles per serial transfer. However, this method could be used with field programmable gate arrays (FPGAs) or application specific integrated circuits (ASICs). Note that this effectively increases the maximum conversion rate of the converter beyond the values given in the specification tables, which assume 16 clock cycles per conversion.

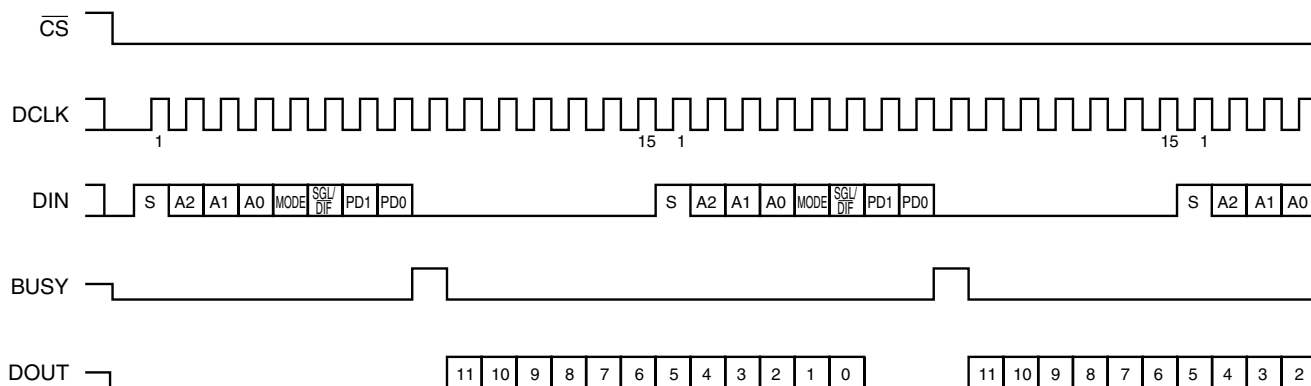
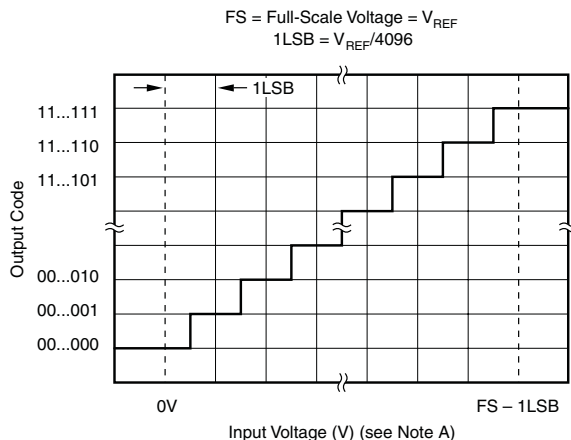

Figure 6. Maximum Conversion Rate, 15 Clock Cycles Per Conversion

### Data Format

The ADS7841 output data is in straight binary format, as shown in Figure 7. This figure shows the ideal output code for the given input voltage and does not include the effects of offset, gain, or noise.



A. Voltage at converter input, after multiplexer: +IN – (–IN). See Figure 2.

Figure 7. Ideal Input Voltages and Output Codes

### 8-Bit Conversion

The ADS7841 provides an 8-bit conversion mode that can be used when faster throughput is needed and the digital result is not as critical. By switching to the 8-bit mode, a conversion is complete four clock cycles earlier. This could be used in conjunction with serial interfaces that provide a 12-bit transfer or two conversions could be accomplished with three 8-bit transfers. Not only does this shorten each conversion by four bits (25% faster throughput), but each conversion can actually occur at a faster clock rate. This is because the internal settling time of the ADS7841 is not as critical, settling to better than 8 bits is all that is needed. The clock rate can be as much as 50% faster. The faster clock rate and fewer clock cycles combine to provide a 2x increase in conversion rate.

### Power Dissipation

There are three power modes for the ADS7841: full power (PD1-PD0 = 11b), auto power-down (PD1-PD0 = 00b), and shutdown ( $\overline{\text{SHDN}}$  low). The affects of these modes varies depending on how the ADS7841 is being operated. For example, at full conversion rate and 16 clocks per conversion, there is very little difference between full power mode and auto power-down. Likewise, if the device has entered auto power-down, a shutdown ( $\overline{\text{SHDN}}$  low) does not lower power dissipation.

When operating at full-speed and 16-clocks per conversion (see Figure 4), the ADS7841 spends most of its time acquiring or converting. There is little time for auto power-down, assuming that this mode is active. Thus, the difference between full power mode and auto power-down is negligible. If the conversion rate is decreased by simply slowing the frequency of the DCLK input, the two modes remain approximately equal. However, if the DCLK frequency is kept at the maximum rate during a conversion, but conversion are simply done less often, then the difference between the two modes is dramatic. Figure 8 shows the difference between reducing the DCLK frequency ("scaling" DCLK to match the conversion rate) or maintaining DCLK at the highest frequency and reducing the number of conversion per second. In the later case, the converter spends an increasing percentage of its time in power-down mode (assuming the auto power-down mode is active).

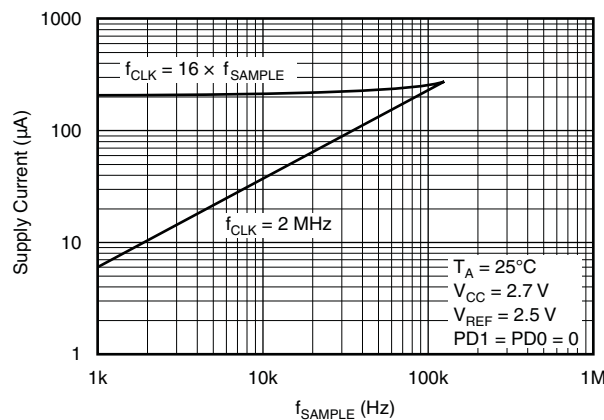

A. Directly scaling the frequency of DCLK with sample rate or keeping DCLK at the maximum possible frequency

**Figure 8. Supply Current vs Sample Rate**

If DCLK is active and  $\overline{\text{CS}}$  is low while the ADS7841 is in auto power-down mode, the device continues to dissipate some power in the digital logic. The power can be reduced to a minimum by keeping CS high. The differences in supply current for these two cases are shown in Figure 9.

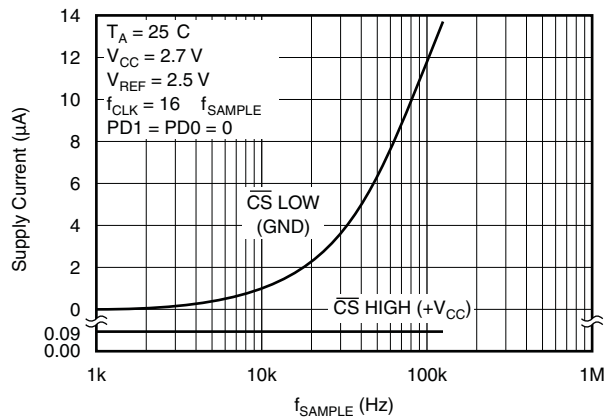

A. Varied with state of  $\overline{\text{CS}}$

**Figure 9. Supply Current vs Sample Rate**

Operating the ADS7841 in auto power-down mode results in the lowest power dissipation, and there is no conversion time "penalty" on power-up. The very first conversion is valid. SHDN can be used to force an immediate power-down.

## PCB Layout

For optimum performance, care should be taken with the physical layout of the ADS7841 circuitry. This is particularly true if the reference voltage is low and/or the conversion rate is high.

The basic SAR architecture is sensitive to glitches or sudden changes on the power supply, reference, ground connections, and digital inputs that occur just prior to latching the output of the analog comparator. Thus, during any single conversion for an n-bit SAR converter, there are n "windows" in which large external transient voltages can easily affect the conversion result. Such glitches might originate from switching power supplies, nearby digital logic, and high power devices. The degree of error in the digital output depends on the reference voltage, layout, and the exact timing of the external event. The error can change if the external event changes in time with respect to the DCLK input.

With this in mind, power to the ADS7841 should be clean and well bypassed. A 0.1- $\mu$ F ceramic bypass capacitor should be placed as close to the device as possible. In addition, a 1- $\mu$ F to 10- $\mu$ F capacitor and a 5 $\Omega$  or 10 $\Omega$  series resistor may be used to low-pass filter a noisy supply.

The reference should be similarly bypassed with a 0.1- $\mu$ F capacitor. Again, a series resistor and large capacitor can be used to low-pass filter the reference voltage. If the reference voltage originates from an op amp, make sure that it can drive the bypass capacitor without oscillation (the series resistor can help in this case). The ADS7841 draws very little current from the reference on average, but it does place larger demands on the reference circuitry over short periods of time (on each rising edge of DCLK during a conversion).

The ADS7841 architecture offers no inherent rejection of noise or voltage variation in regards to the reference input. This is of particular concern when the reference input is tied to the power supply. Any noise and ripple from the supply appears directly in the digital results. While high-frequency noise can be filtered out as discussed in the previous paragraph, voltage variation due to line frequency (50 Hz or 60 Hz) can be difficult to remove.

The GND pin should be connected to a clean ground point. In many cases, this is the "analog" ground. Avoid connections that are too near the grounding point of a microcontroller or digital signal processor. If needed, run a ground trace directly from the converter to the power supply entry point. The ideal layout includes an analog ground plane dedicated to the converter and associated analog circuitry.

**PACKAGING INFORMATION**

Orderable Device	Status <sup>(1)</sup>	Package Type	Package Drawing	Pins	Package Qty	Eco Plan <sup>(2)</sup>	Lead/ Ball Finish	MSL Peak Temp <sup>(3)</sup>	Samples (Requires Login)
ADS7841EIDBQRQ1	ACTIVE	SSOP/QSOP	DBQ	16	2500	Green (RoHS & no Sb/Br)	CU NIPDAU	Level-2-260C-1 YEAR	
ADS7841ESQDBQRQ1	PREVIEW	SSOP/QSOP	DBQ	16	2500	TBD	Call TI	Call TI	

<sup>(1)</sup> The marketing status values are defined as follows:

**ACTIVE:** Product device recommended for new designs.

**LIFEBUY:** TI has announced that the device will be discontinued, and a lifetime-buy period is in effect.

**NRND:** Not recommended for new designs. Device is in production to support existing customers, but TI does not recommend using this part in a new design.

**PREVIEW:** Device has been announced but is not in production. Samples may or may not be available.

**OBSELETE:** TI has discontinued the production of the device.

<sup>(2)</sup> Eco Plan - The planned eco-friendly classification: Pb-Free (RoHS), Pb-Free (RoHS Exempt), or Green (RoHS & no Sb/Br) - please check <http://www.ti.com/productcontent> for the latest availability information and additional product content details.

**TBD:** The Pb-Free/Green conversion plan has not been defined.

**Pb-Free (RoHS):** TI's terms "Lead-Free" or "Pb-Free" mean semiconductor products that are compatible with the current RoHS requirements for all 6 substances, including the requirement that lead not exceed 0.1% by weight in homogeneous materials. Where designed to be soldered at high temperatures, TI Pb-Free products are suitable for use in specified lead-free processes.

**Pb-Free (RoHS Exempt):** This component has a RoHS exemption for either 1) lead-based flip-chip solder bumps used between the die and package, or 2) lead-based die adhesive used between the die and leadframe. The component is otherwise considered Pb-Free (RoHS compatible) as defined above.

**Green (RoHS & no Sb/Br):** TI defines "Green" to mean Pb-Free (RoHS compatible), and free of Bromine (Br) and Antimony (Sb) based flame retardants (Br or Sb do not exceed 0.1% by weight in homogeneous material)

<sup>(3)</sup> MSL, Peak Temp. -- The Moisture Sensitivity Level rating according to the JEDEC industry standard classifications, and peak solder temperature.

**Important Information and Disclaimer:** The information provided on this page represents TI's knowledge and belief as of the date that it is provided. TI bases its knowledge and belief on information provided by third parties, and makes no representation or warranty as to the accuracy of such information. Efforts are underway to better integrate information from third parties. TI has taken and continues to take reasonable steps to provide representative and accurate information but may not have conducted destructive testing or chemical analysis on incoming materials and chemicals. TI and TI suppliers consider certain information to be proprietary, and thus CAS numbers and other limited information may not be available for release.

In no event shall TI's liability arising out of such information exceed the total purchase price of the TI part(s) at issue in this document sold by TI to Customer on an annual basis.

**OTHER QUALIFIED VERSIONS OF ADS7841-Q1 :**

- Catalog: [ADS7841](#)

NOTE: Qualified Version Definitions:

- Catalog - TI's standard catalog product

## TAPE AND REEL INFORMATION

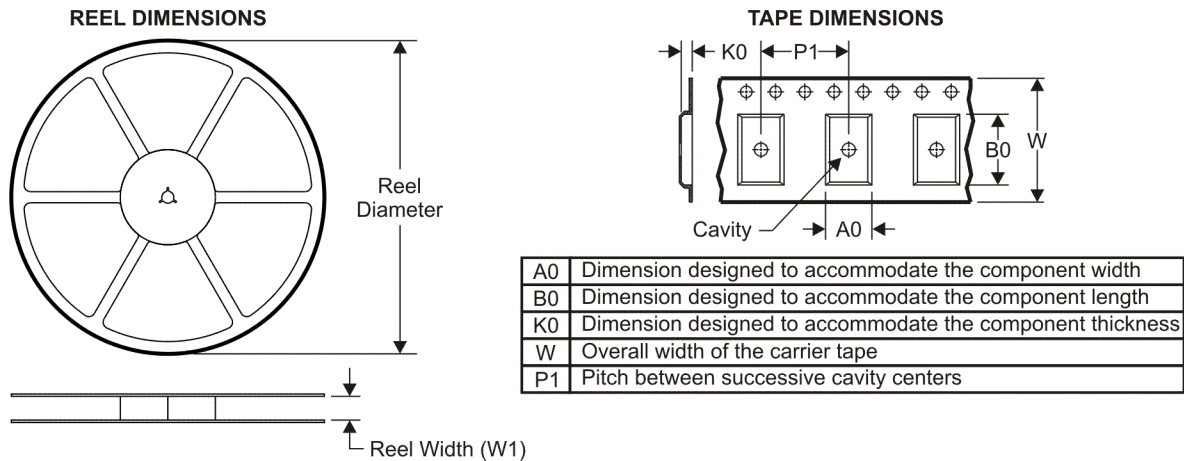

### QUADRANT ASSIGNMENTS FOR PIN 1 ORIENTATION IN TAPE

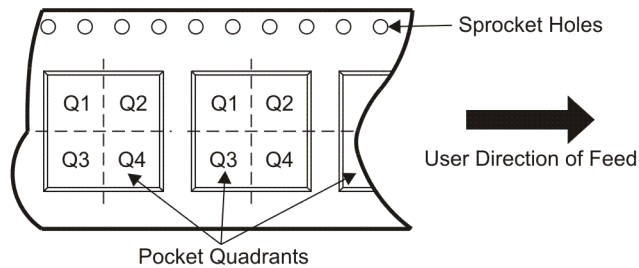

\*All dimensions are nominal

Device	Package Type	Package Drawing	Pins	SPQ	Reel Diameter (mm)	Reel Width W1 (mm)	A0 (mm)	B0 (mm)	K0 (mm)	P1 (mm)	W (mm)	Pin1 Quadrant
ADS7841EIDBQRQ1	SSOP/QSOP	DBQ	16	2500	330.0	12.4	6.4	5.2	2.1	8.0	12.0	Q1

**TAPE AND REEL BOX DIMENSIONS**



\*All dimensions are nominal

Device	Package Type	Package Drawing	Pins	SPQ	Length (mm)	Width (mm)	Height (mm)
ADS7841EIDBQRQ1	SSOP/QSOP	DBQ	16	2500	346.0	346.0	29.0





## IMPORTANT NOTICE

Texas Instruments Incorporated and its subsidiaries (TI) reserve the right to make corrections, modifications, enhancements, improvements, and other changes to its products and services at any time and to discontinue any product or service without notice. Customers should obtain the latest relevant information before placing orders and should verify that such information is current and complete. All products are sold subject to TI's terms and conditions of sale supplied at the time of order acknowledgment.

TI warrants performance of its hardware products to the specifications applicable at the time of sale in accordance with TI's standard warranty. Testing and other quality control techniques are used to the extent TI deems necessary to support this warranty. Except where mandated by government requirements, testing of all parameters of each product is not necessarily performed.

TI assumes no liability for applications assistance or customer product design. Customers are responsible for their products and applications using TI components. To minimize the risks associated with customer products and applications, customers should provide adequate design and operating safeguards.

TI does not warrant or represent that any license, either express or implied, is granted under any TI patent right, copyright, mask work right, or other TI intellectual property right relating to any combination, machine, or process in which TI products or services are used. Information published by TI regarding third-party products or services does not constitute a license from TI to use such products or services or a warranty or endorsement thereof. Use of such information may require a license from a third party under the patents or other intellectual property of the third party, or a license from TI under the patents or other intellectual property of TI.

Reproduction of TI information in TI data books or data sheets is permissible only if reproduction is without alteration and is accompanied by all associated warranties, conditions, limitations, and notices. Reproduction of this information with alteration is an unfair and deceptive business practice. TI is not responsible or liable for such altered documentation. Information of third parties may be subject to additional restrictions.

Resale of TI products or services with statements different from or beyond the parameters stated by TI for that product or service voids all express and any implied warranties for the associated TI product or service and is an unfair and deceptive business practice. TI is not responsible or liable for any such statements.

TI products are not authorized for use in safety-critical applications (such as life support) where a failure of the TI product would reasonably be expected to cause severe personal injury or death, unless officers of the parties have executed an agreement specifically governing such use. Buyers represent that they have all necessary expertise in the safety and regulatory ramifications of their applications, and acknowledge and agree that they are solely responsible for all legal, regulatory and safety-related requirements concerning their products and any use of TI products in such safety-critical applications, notwithstanding any applications-related information or support that may be provided by TI. Further, Buyers must fully indemnify TI and its representatives against any damages arising out of the use of TI products in such safety-critical applications.

TI products are neither designed nor intended for use in military/aerospace applications or environments unless the TI products are specifically designated by TI as military-grade or "enhanced plastic." Only products designated by TI as military-grade meet military specifications. Buyers acknowledge and agree that any such use of TI products which TI has not designated as military-grade is solely at the Buyer's risk, and that they are solely responsible for compliance with all legal and regulatory requirements in connection with such use.

TI products are neither designed nor intended for use in automotive applications or environments unless the specific TI products are designated by TI as compliant with ISO/TS 16949 requirements. Buyers acknowledge and agree that, if they use any non-designated products in automotive applications, TI will not be responsible for any failure to meet such requirements.

Following are URLs where you can obtain information on other Texas Instruments products and application solutions:

### Products

Audio	<a href="http://www.ti.com/audio">www.ti.com/audio</a>
Amplifiers	<a href="http://amplifier.ti.com">amplifier.ti.com</a>
Data Converters	<a href="http://dataconverter.ti.com">dataconverter.ti.com</a>
DLP® Products	<a href="http://www.dlp.com">www.dlp.com</a>
DSP	<a href="http://dsp.ti.com">dsp.ti.com</a>
Clocks and Timers	<a href="http://www.ti.com/clocks">www.ti.com/clocks</a>
Interface	<a href="http://interface.ti.com">interface.ti.com</a>
Logic	<a href="http://logic.ti.com">logic.ti.com</a>
Power Mgmt	<a href="http://power.ti.com">power.ti.com</a>
Microcontrollers	<a href="http://microcontroller.ti.com">microcontroller.ti.com</a>
RFID	<a href="http://www.ti-rfid.com">www.ti-rfid.com</a>
RF/IF and ZigBee® Solutions	<a href="http://www.ti.com/lprf">www.ti.com/lprf</a>

### Applications

Communications and Telecom	<a href="http://www.ti.com/communications">www.ti.com/communications</a>
Computers and Peripherals	<a href="http://www.ti.com/computers">www.ti.com/computers</a>
Consumer Electronics	<a href="http://www.ti.com/consumer-apps">www.ti.com/consumer-apps</a>
Energy and Lighting	<a href="http://www.ti.com/energy">www.ti.com/energy</a>
Industrial	<a href="http://www.ti.com/industrial">www.ti.com/industrial</a>
Medical	<a href="http://www.ti.com/medical">www.ti.com/medical</a>
Security	<a href="http://www.ti.com/security">www.ti.com/security</a>
Space, Avionics and Defense	<a href="http://www.ti.com/space-avionics-defense">www.ti.com/space-avionics-defense</a>
Transportation and Automotive	<a href="http://www.ti.com/automotive">www.ti.com/automotive</a>
Video and Imaging	<a href="http://www.ti.com/video">www.ti.com/video</a>
Wireless	<a href="http://www.ti.com/wireless-apps">www.ti.com/wireless-apps</a>

TI E2E Community Home Page

[e2e.ti.com](http://e2e.ti.com)

Mailing Address: Texas Instruments, Post Office Box 655303, Dallas, Texas 75265  
Copyright © 2011, Texas Instruments Incorporated